



5252 East 36th Street North
Wichita, KS USA 67220-3205
TEL: 316-686-7361
FAX: 316-686-6746

GREAT PLAINS INDUSTRIES, INC.

"A Great Plains Ventures Subsidiary"

www.gpi.net

1-800-835-0113

HP-90 Petroleum Hand Pump

Owner's Manual

STOP

**DO NOT RETURN
THIS PRODUCT
TO THE STORE!**

Please contact GPI before returning any product. If you are missing parts or experience problems with your installation, our Customer Support Department will be happy to assist you.

GPI Customer Support
**800-835-0113 or
316-686-7361**

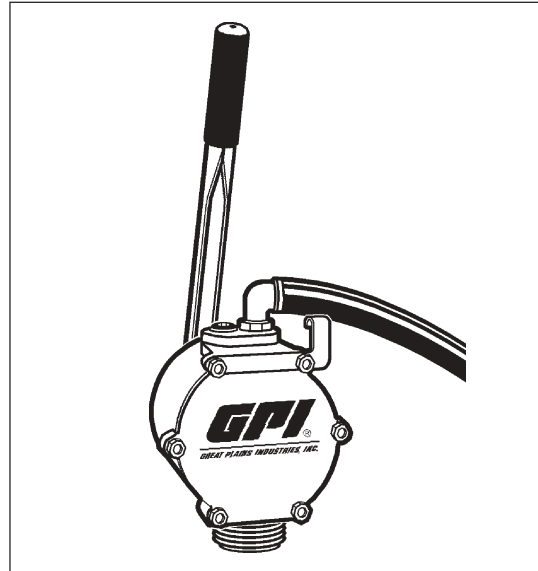

WARNING

This product shall not be used for pumping fuel or other liquids into aircraft.

INSTALLATION

Know and follow applicable national, state and local safety codes pertaining to installing and operating equipment for use with petroleum fluids

Make sure the tank is vented to prevent the buildup of pressure and possible fuel leakage through the nozzle.

Use the following procedures to install the HP-90 Hand Pump on a tank with a 2-inch NPT bung.

Install Suction Pipe

1. Place PVC pipe into flared end of PVC pipe assembly. Use PVC cement if desired. The end of the pipe should be 2-3 inches above the bottom of the tank, when installed correctly. Cut pipe to fit tank.
2. Remove the two protective plugs from the inlet and outlet ports.
3. Wrap the threaded end of the suction pipe with 3 to 4 turns of Teflon® tape.

4. Install the suction pipe into the pump inlet and tighten with a wrench.

Install Pump on Tank

1. Lubricate the male threads on the pump inlet with Teflon® tape or a thread-sealing compound approved for use with petroleum fuels.
2. Thread the pump onto the tank and turn pump to tighten securely.

Install Handle

1. Slide the grip onto the pump handle.
2. Install one end of the link in the pump housing, the other end in the bottom hole in the pump handle. Connect the pump handle to the shaft with the clevis pin and secure with the cotter pin.

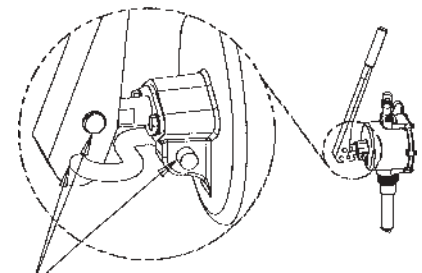

Lubricate all Pin Joints with grease to extend the life of your hand pump.

OPERATIONS

Observe safety precautions when handling fuel:

- Keep fuel away from open flame or spark.
- Do not refuel vehicles or equipment with engines running or while engine is hot.
- Do not smoke while refueling.
- Know and follow all safety precautions when handling petroleum fluids
- Insure that all equipment operators have access to adequate instructions concerning safe operating and maintenance procedures.

To Dispense Fluid

1. Remove the nozzle from its holder and insert into the receiving tank of the equipment or vehicle.
2. To pump, manually move the handle front to back as shown on right.
3. Return the handle to its upright storage position, after dispensing the desired amount of fluid. Drain the hose and place the nozzle in its holder.

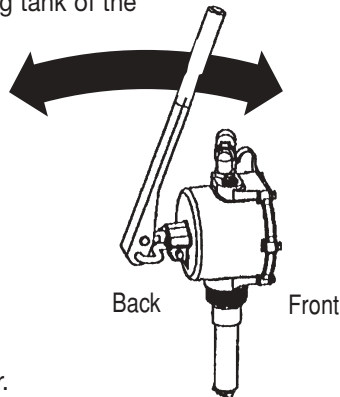

TROUBLESHOOTING

- A. **Shaft Seal Leak**
1. **Seal worn.** Replace (Seal Kit 131501-02).
- B. **Anti-Siphon Vent Leak**
1. **Vent damaged.** Remove and clean or replace (Kit 123504-1).
- C. **Low Flowrate**
1. **Inlet screen clogged.** Remove pump and suction pipe, clean screen and re-install.
 2. **Suction pipe leak.** Repair or replace as needed.
 3. **Piston seals worn.** Replace (Seal Kit 131501-02).

SPECIFICATIONS

The GPI HP-90 Petroleum Hand Pump is designed to manually pump petroleum products such as diesel fuel, kerosene and gasoline and fits any container with a 2-inch NPT bung.

Construction:	Lightweight aluminum housing, stainless steel shaft and plastic piston
Capacity:	Up to 1 quart per stroke
Inlet Port:	1 inch NPT
Inlet Screen:	Integral with pump
Outlet Port:	3/4 inch NPT
Hose and Nozzle:	3/4 inch x 8 foot Buna-N hose. Thermoplastic unleaded nozzle
Suction Pipe:	2 piece PVC
Shipping Weight:	12.8 pounds (5.8 kg)

SERVICE

For warranty consideration or other service information, please contact your local distributor. If you need further assistance, contact the GPI Customer Service Department in Wichita, Kansas, during normal business hours. A toll free number is provided for your convenience.

1-800-835-0113

To obtain prompt, efficient service, always be prepared with the following information:

1. The model number of your pump.
2. The manufacturing date code of your pump.

For the HP-90, the date code is located on the shaft side of the pump housing.

For warranty work, always be prepared with your original sales slip or other evidence of purchase date.

Please contact GPI before returning any pump. It may be possible to diagnose the trouble and find a solution with a telephone call. GPI can also inform you of any special requirements you will need to follow for shipping.



!!! CAUTION !!!

Do not return the pump without authority from the Customer Service Department. Due to strict government regulations, GPI cannot accept pumps unless they have been drained and cleaned.

ILLUSTRATED PARTS DRAWING

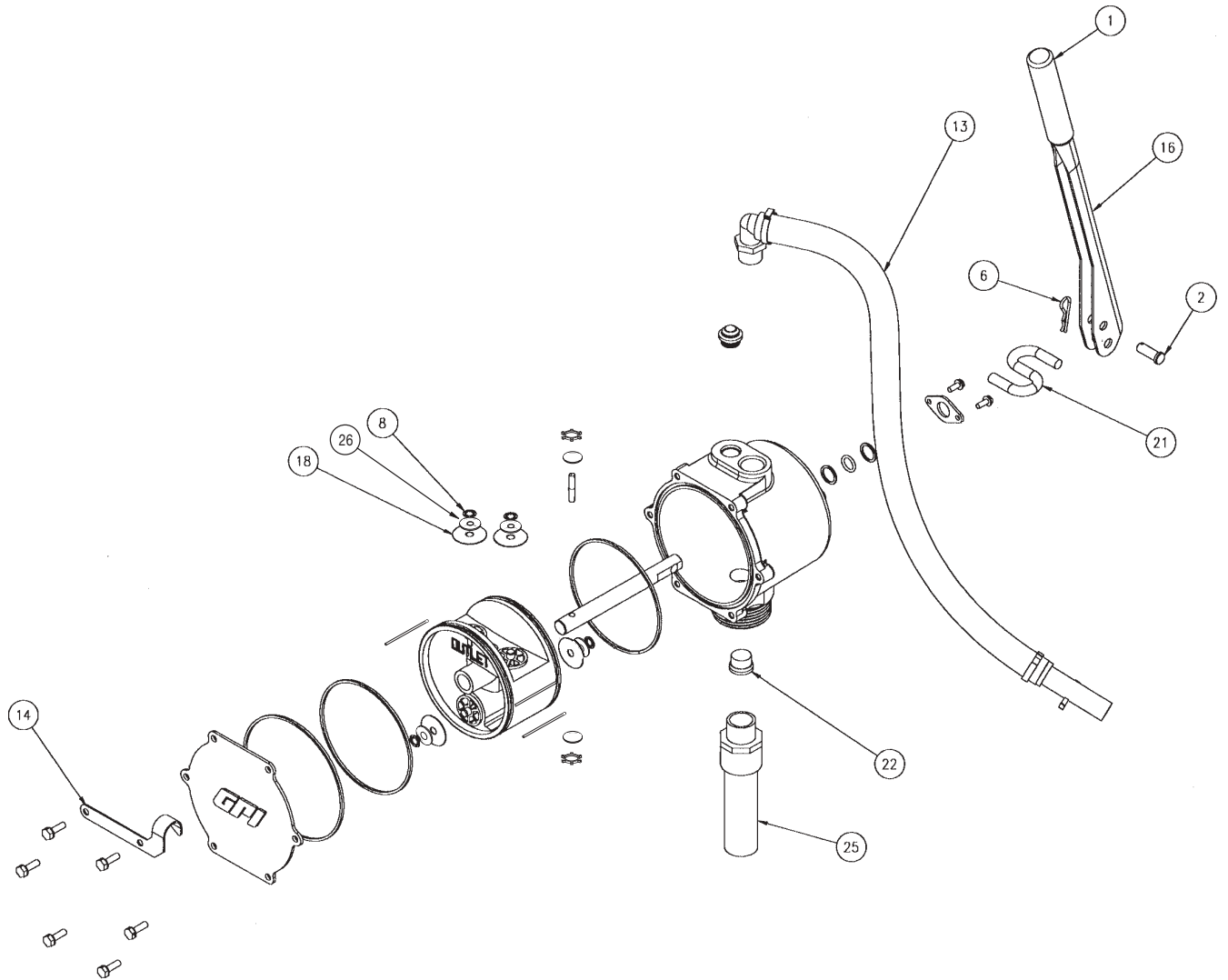

Kits and Accessories

- 131501-02 Seal Kit includes PTFE inserts, shaft, piston, and coverplate seals.
- 123504-1 Anti-siphon Vent Kit.

Item No.	Part No.	Description	No. Req'd.
1	906001-43	Handle Grip	1
2	904006-32	Clevis Pin, 3/8 in.	1
6	904002-58	Hitch Clip Pin	1
8	904001-55	Retaining Ring	4
13	131034-1	Fuel Hose Assembly, 3/4 in.	1
14	131033-1	Nozzle Bracket	1
16	131031-1	Handle	1
18	131039-1	Flapper Valve	4
21	131022-1	Link	1
22	123038-1	Inlet Screen	1
25	110264-3	Suction Pipe, Upper Portion	1
	110263-1	Suction Pipe, Lower Portion	1
26	904006-69	Washer, Flat	4

Limited Warranty Policy

Great Plains Industries, Inc. 5252 E. 36th Street North, Wichita, KS USA 67220-3205, hereby provides a limited warranty against defects in material and workmanship on all products manufactured by Great Plains Industries, Inc. This product includes a 2 year warranty. Manufacturer's sole obligation under the foregoing warranties will be limited to either, at Manufacturer's option, replacing or repairing defective Goods (subject to limitations hereinafter provided) or refunding the purchase price for such Goods theretofore paid by the Buyer, and Buyer's exclusive remedy for breach of any such warranties will be enforcement of such obligations of Manufacturer. The warranty shall extend to the purchaser of this product and to any person to whom such product is transferred during the warranty period.

The warranty period shall begin on the date of manufacture or on the date of purchase with an original sales receipt. This warranty shall not apply if:

- A. the product has been altered or modified outside the warrantor's duly appointed representative;
- B. the product has been subjected to neglect, misuse, abuse or damage or has been installed or operated other than in accordance with the manufacturer's operating instructions.

To make a claim against this warranty, contact the GPI Customer Service Department at 316-686-7361 or 800-835-0113. Or by mail at:
Great Plains Industries, Inc.
5252 E. 36th St. North
Wichita, KS, USA 67220-3205

The company shall, notify the customer to either send the product, transportation prepaid, to the company at its office in Wichita, Kansas, or to a duly authorized service center. The company shall perform all obligations imposed on it by the terms of this warranty within 60 days of receipt of the defective product.

GREAT PLAINS INDUSTRIES, INC., EXCLUDES LIABILITY UNDER THIS WARRANTY FOR DIRECT, INDIRECT, INCIDENTAL AND CONSEQUENTIAL DAMAGES INCURRED IN THE USE OR LOSS OF USE OF THE PRODUCT WARRANTED HEREUNDER.

The company herewith expressly disclaims any warranty of merchantability or fitness for any particular purpose other than for which it was designed.

This warranty gives you specific rights and you may also have other rights which vary from U.S. state to U.S. state.

Note: In compliance with MAGNUSON MOSS CONSUMER WARRANTY ACT – Part 702 (governs the resale availability of the warranty terms).



5252 East 36th Street North
Wichita, KS USA 67220-3205
TEL: 316-686-7361
FAX: 316-686-6746

GREAT PLAINS INDUSTRIES, INC.

"A Great Plains Ventures Subsidiary"

www.gpi.net

1-800-835-0113